

Who was William Rollins

and what can we learn?

Stuart C. White

UCLA

Presented to AAOMR in Nov. 2005

# Setting the Scene

15 BY BP: Big Bang

4.6 BY BP: Solar system evolved

100,000 BP: Homo sapiens evolved

1830: Gas tubes invented



# Michael Faraday 1791-1867



1830

Studied effects of electric current on gas

- Tube was filled with a gas
- Metal plates were connected to series of batteries
- Gas slowly pumped out of tube
- When the gas pressure became small enough, the gas began to glow

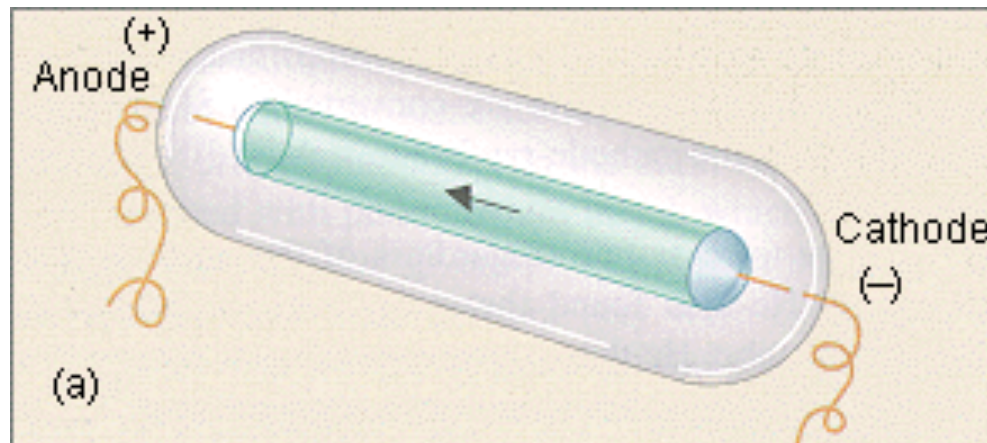

# Heinrich Geissler tubes

mid-1800's

- Built improved vacuum pumps
- Produce low-pressure gas tubes in a variety of sizes, shapes, and configurations



# Julius Plucker 1801 - 1868



1858

- Noted that when residual pressure of gas inside cathode-ray tube is small, the glass at one end of tube emits light
- Could change position of patch of glass that glowed by bringing a magnet close to the tube
- Whatever produced this glow is electrically charged

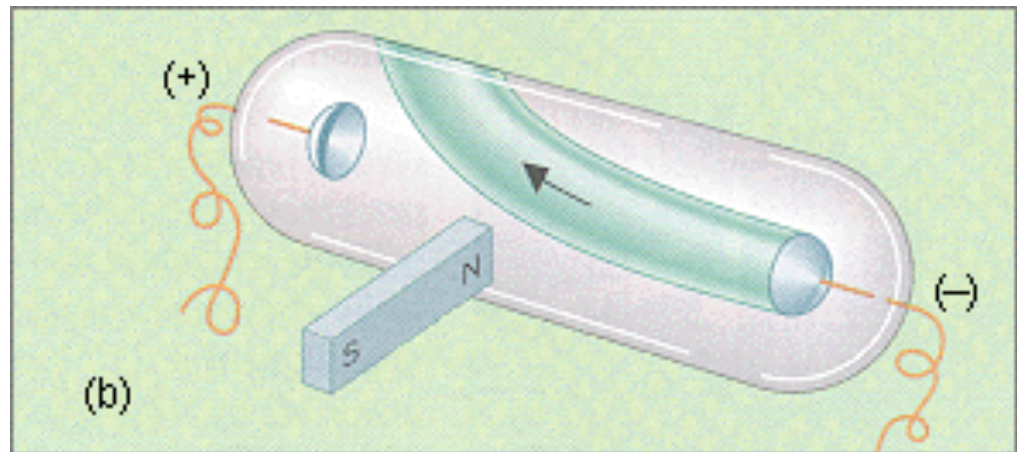

# Rühmkorff spark inductor

1860's onward - provided higher voltages

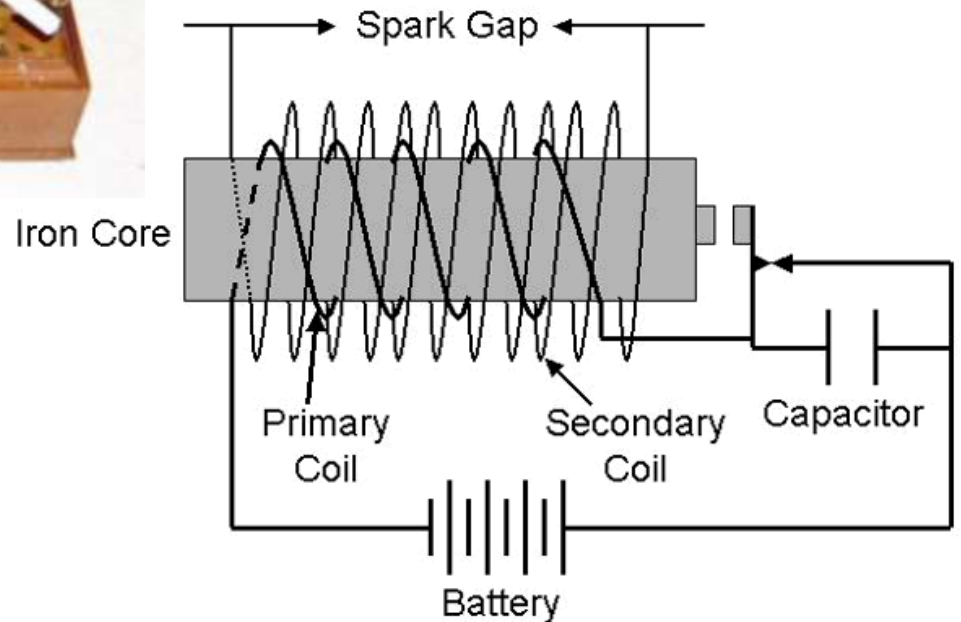

# Rühmkorff coil + Geissler tube



# Johannes Hittorf - 1860s

Noted that in high vacuum tubes glow extends from negative electrode and produce a fluorescent glow if it strikes the glass walls of the tube

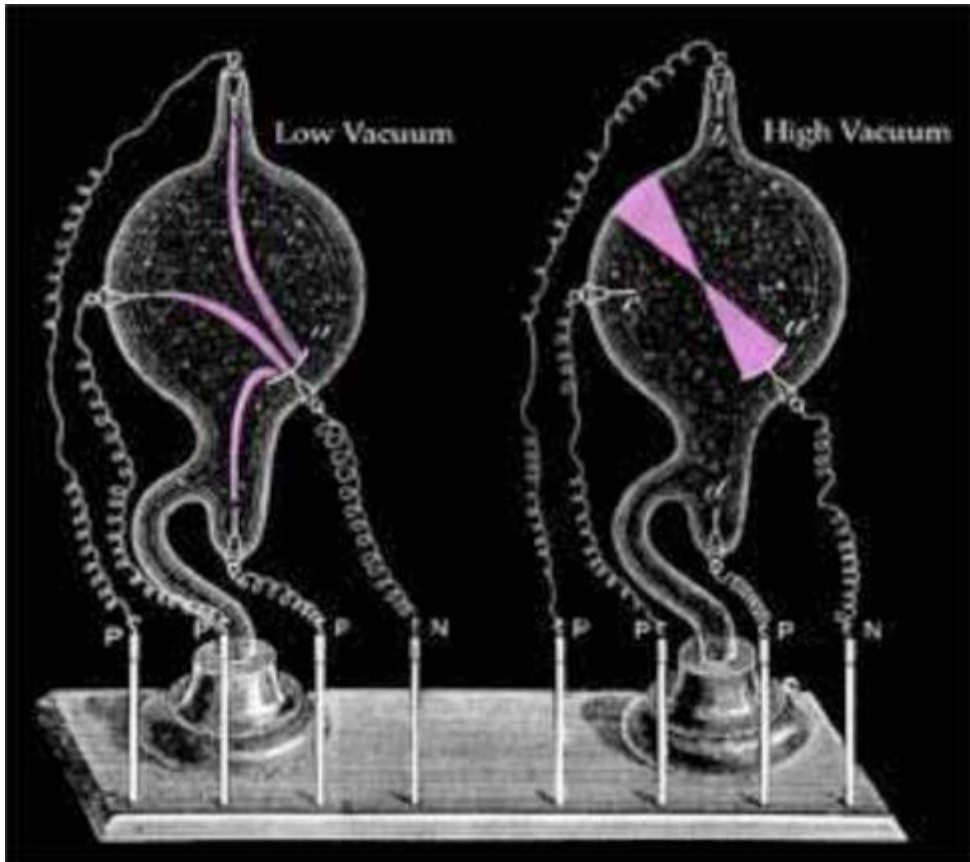
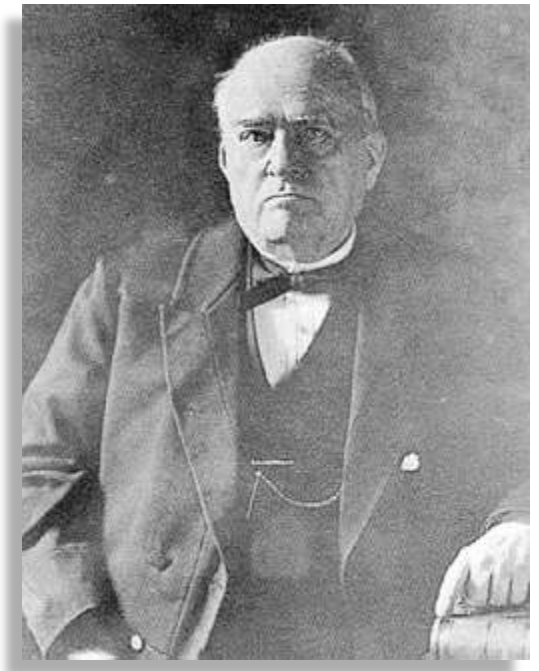

# Johannes Hittorf

1869

- When a solid object is placed between cathode and anode a shadow is cast on the end of the tube across from the cathode
- This suggests that some beam or ray is given off by the cathode; these tubes soon became known as cathode-ray tubes

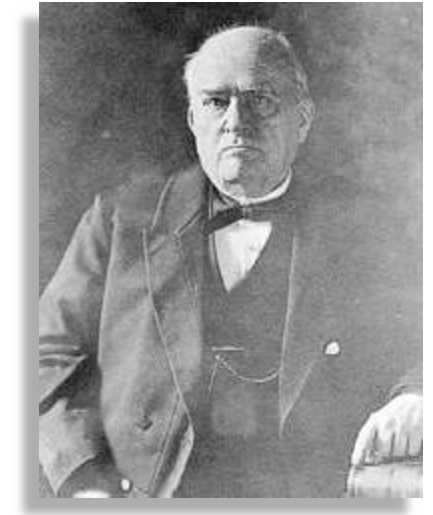

# William Crookes

Confirmed previous work by Plucker and Hittorf, and showed that cathode rays are *negatively* charged by studying the direction in which cathode rays are deflected by a magnetic field



# Hertz & his student Lenard

## Lenard Tube 1892

- Heinrich Hertz found that cathode rays could penetrate tube
- Lenard developed a tube with a thin foil window through which cathode rays could pass into atmosphere
- He studied penetration of these rays through various materials

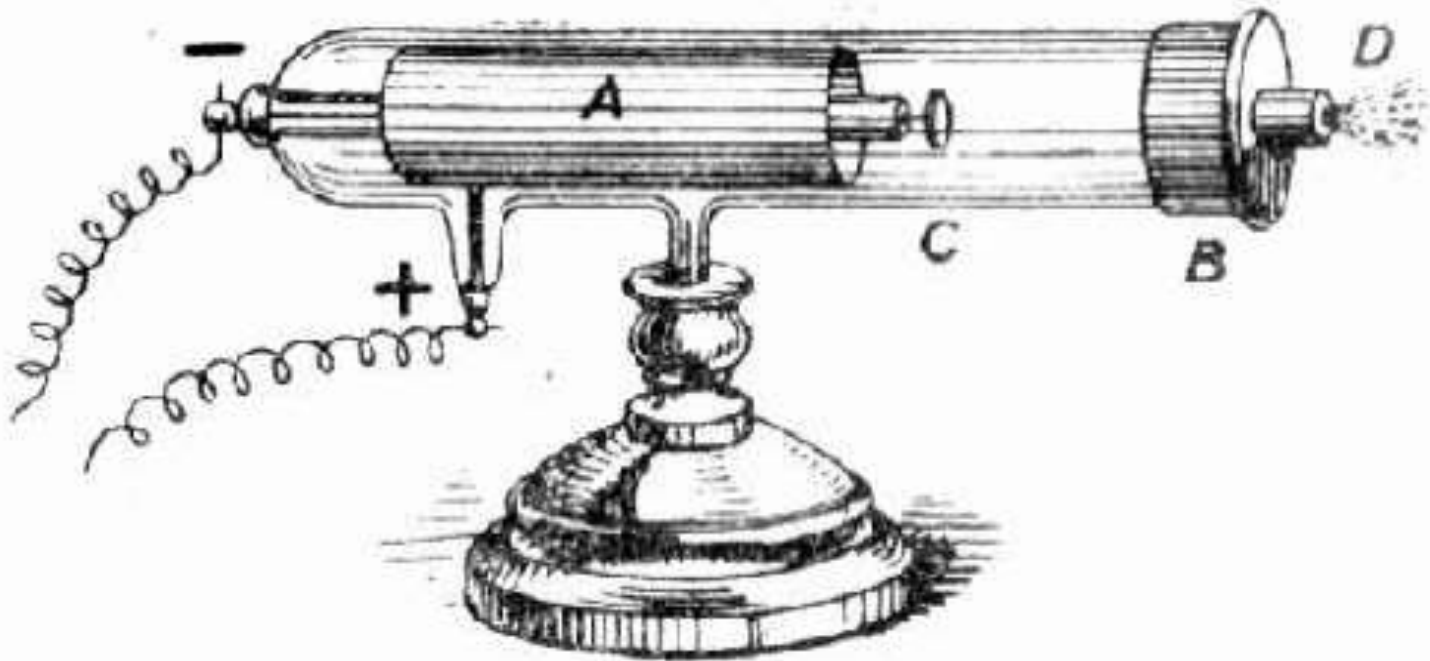

# Lenard

- Cathode rays can penetrate glass and travel a few cm in air
  - Can cause fluorescence in various salts, including barium platinocyanide
  - Can darken photographic film



# Röntgen

- May 1895 Röntgen decides to repeat Hertz and Lenard's work
- Interested in cathode rays which travel outside of tubes
- Uses barium platinocyanide, which will fluoresce, as his detector

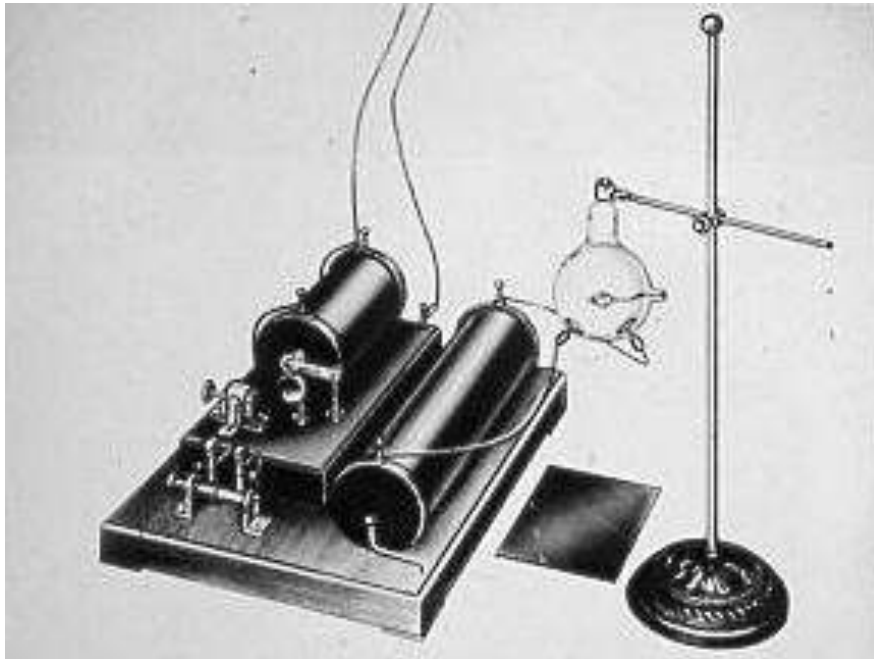

# Barium platinocyanide



# Röntgen's lab

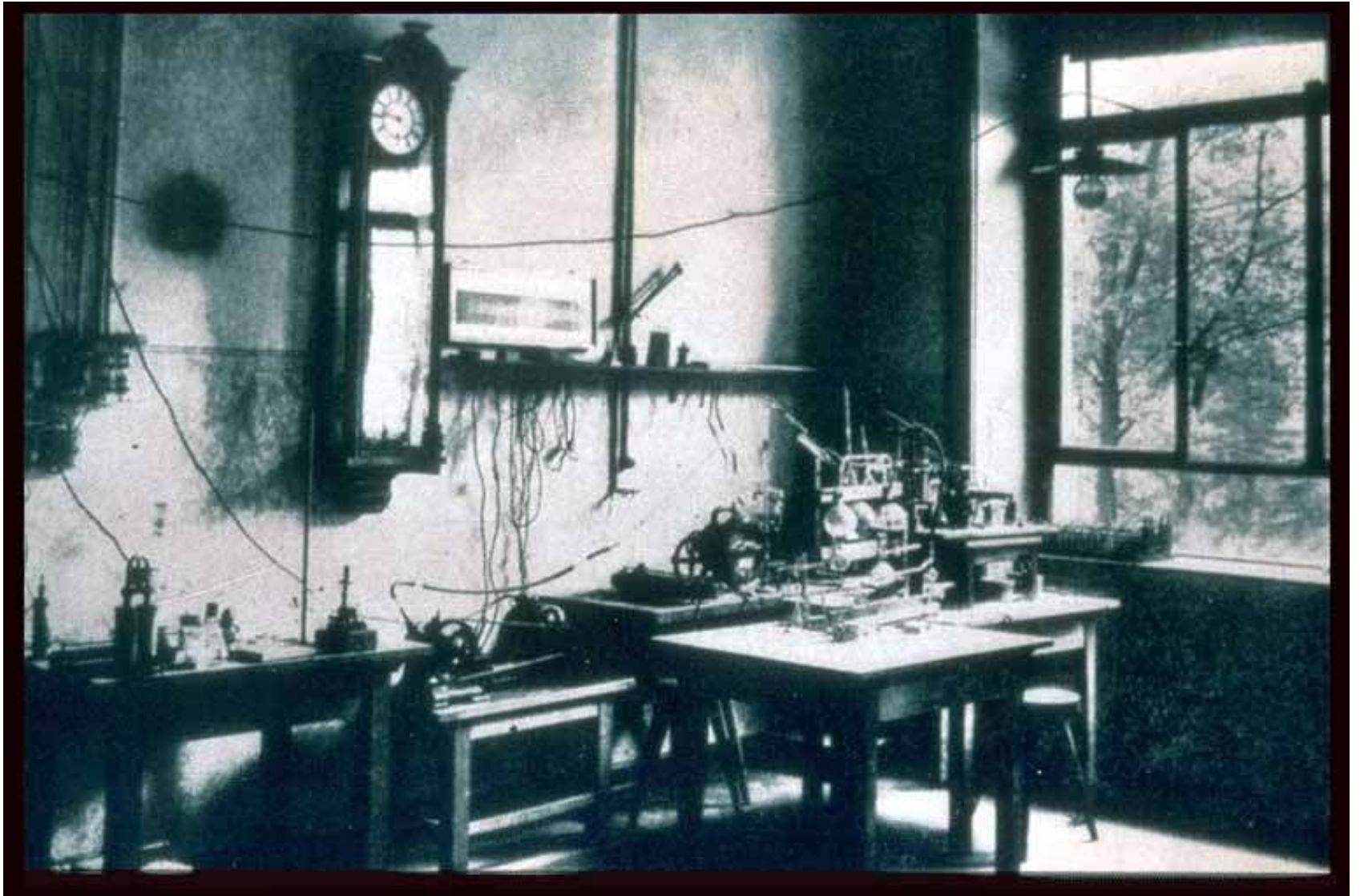

# Expected



Close the drapes

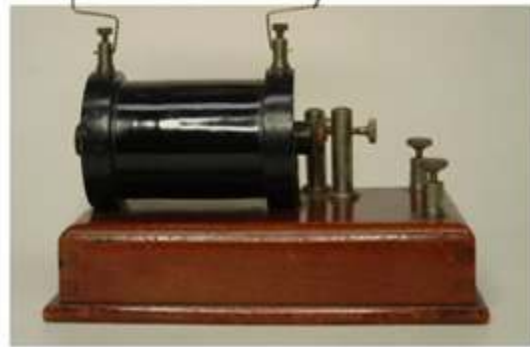

1. Now tries thick glass tube
2. Covers tube to block fluorescence from tube
3. Closes drapes
4. Powers up tube
5. Goes to get screen
6. And observes ...

# Unexpected

Black paper

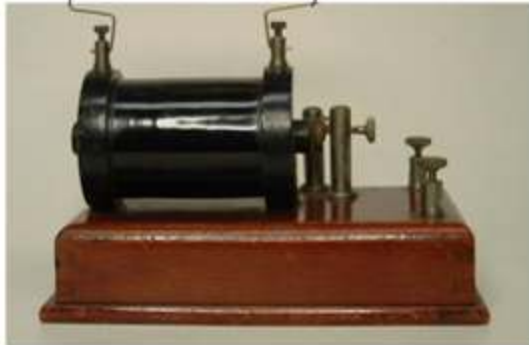

Close the drapes



Glowing screen  
2 meters away!



# Radiations blocked by objects

- Röntgen announced his discovery “On a New Kind of Rays” in December 1895
- Concludes that these rays are different from cathode rays

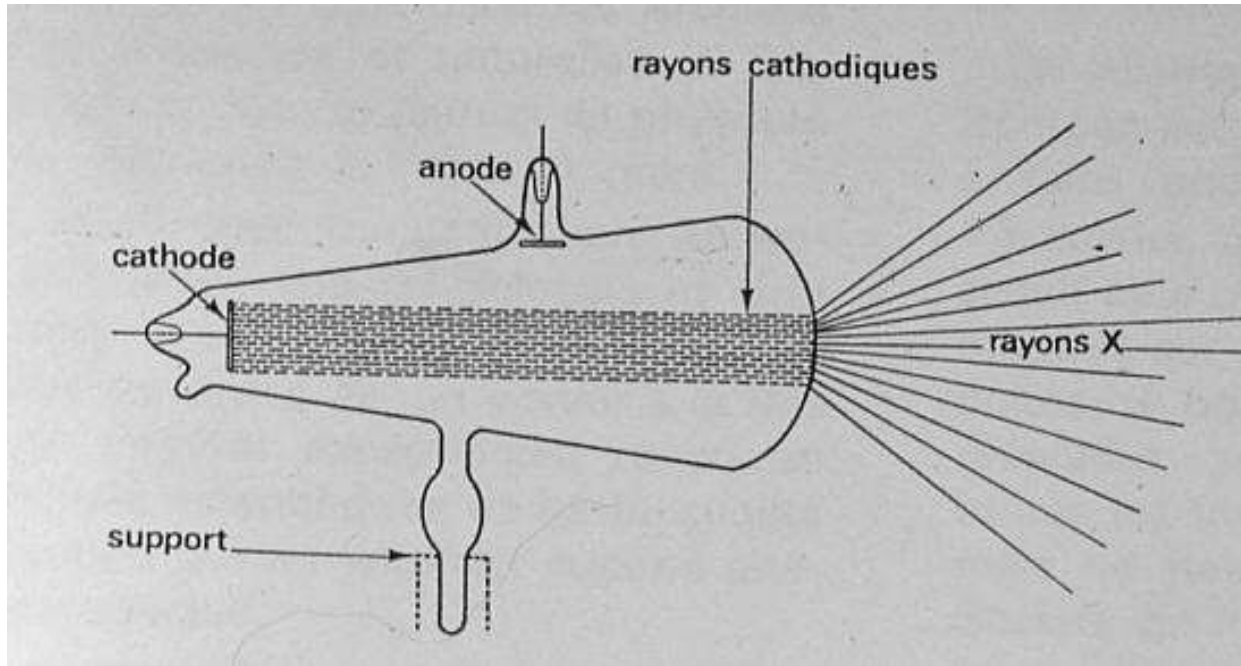

Or his hand

# Bertha



# Röntgen becomes a star



## Little lessons in life #1

- Frederick Smith, Oxford physicist, found fogged photographic plates near tube - told his assistant to move plates
- J. J. Thomson, discovered electron at Cavendish Lab at Cambridge in 1897, noticed fluorescence in glass tubing several feet from cathode-ray tube - but more interested in the cathode rays

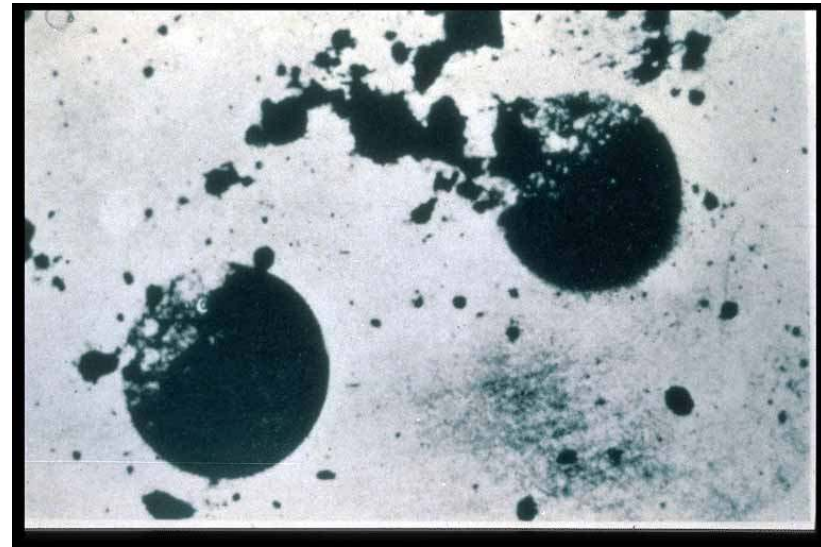

- Prof. Goodspeed U. Penn (1890)

In fields of observation, chance favors only the prepared mind  
Louis Pasteur

# Immediate public acceptance

WONDERFUL NEW RAY  
SEES THROUGH HAND!

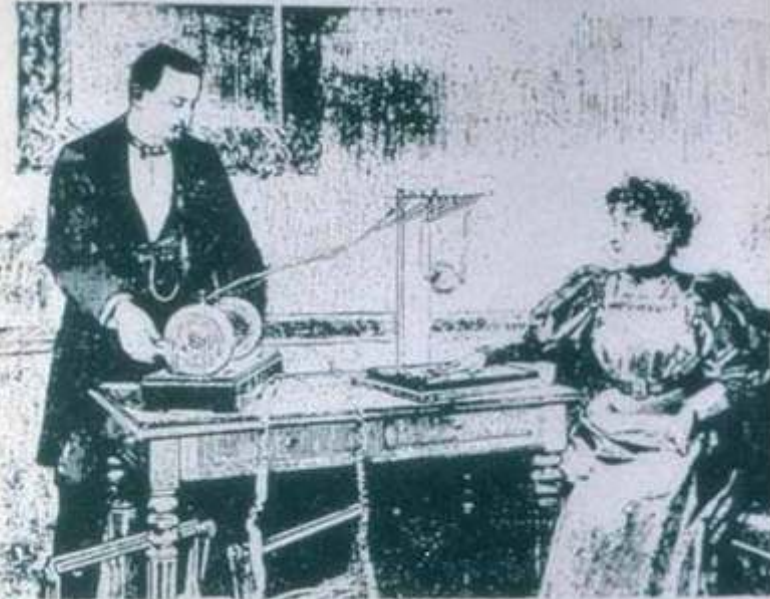

*X-Ray Studio . . .*  
*110 East Twenty-Sixty Street,*  
*....New York C*

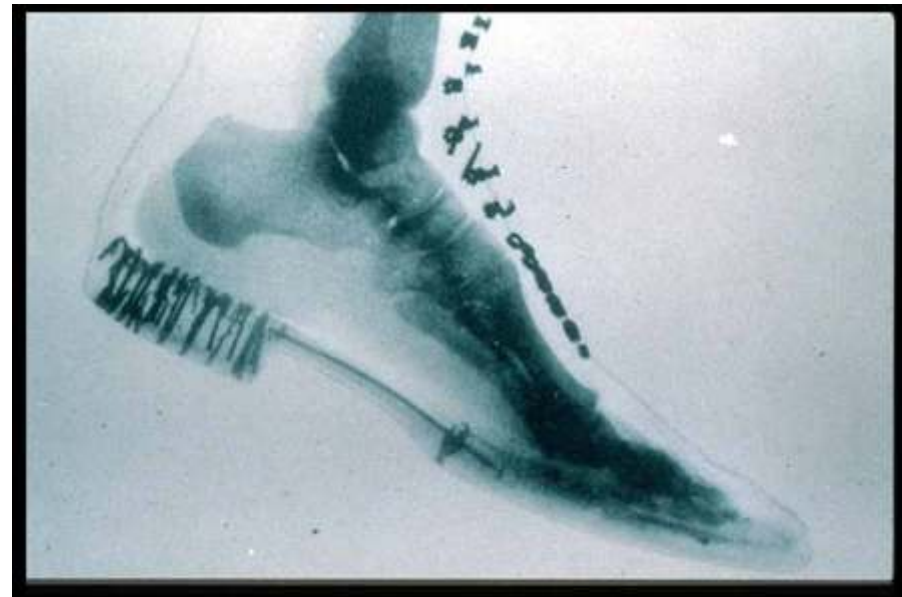

# Do-it-yourself!

- 1896 newspaper advertisement for a radiologic equipment
- Everybody can buy a Crook's tube with an induction coil at the "Comptoir general de la photographie"

APPAREILS ET USTENSILES POUR  
**Expériences avec les rayons X  
de Röntgen**  
— (PHOTOGRAPHIE DE L'INVISIBLE) —  
**RICHARD, CH. HELLER et C<sup>ie</sup>**  
Fabrique d'Appareils d'Electricité militaire et industrielle, 18, Cité Trévise, PARIS  
Nous demandons, à cause des nombreuses commandes, un délai de  
livraison de 8 à 10 jours. — **CHARGE DES ACCUMULATEURS A FORFAIT**

**MATÉRIEL COMPLET**  
Pour répéter les expériences  
DU  
**Professeur ROËNTGEN**  
**PHOTOGRAPHIE**  
à travers les  
**CORPS OPAQUES**   
*Succès garanti*

 *(envoi franco de la Belgique sur commande)*  
57, rue Saint-Roch, 57  
— PARIS

# Pop icon

The Roentgen Rays, the Roentgen Rays,  
What is this craze?  
The town's ablaze  
With the new phase  
Of X-ray's ways.

I'm full of daze,  
Shock and amaze;  
For now adays I hear they'll gaze  
Through cloak and gown and even stays,  
Those naughty, naughty Roentgen Rays.

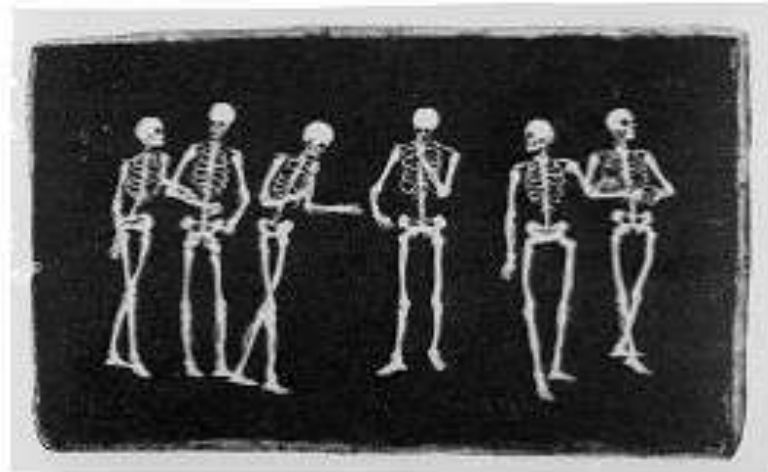

# Uncritical acceptance

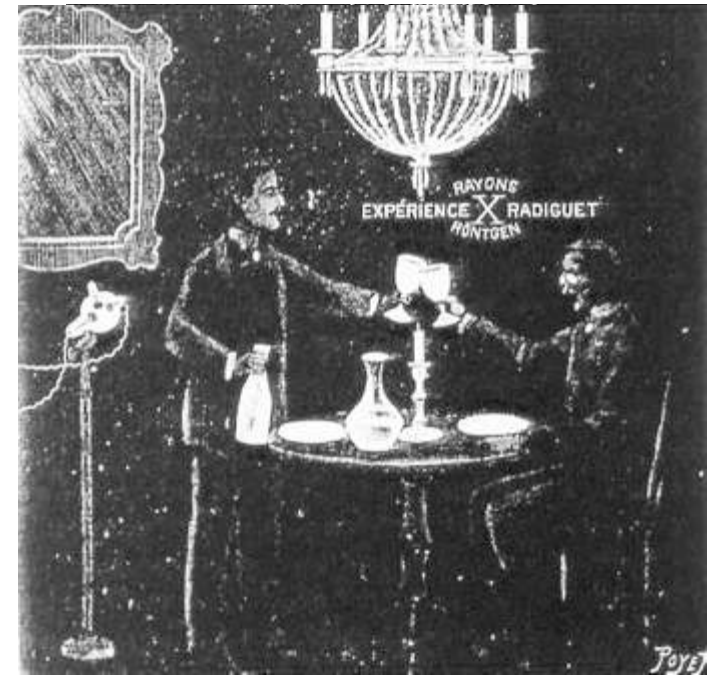

**"First radiograph of the human brain"  
1896**

In reality a pan of cat intestines  
photographed by H.A. Falk



# Bitewings of Dr. Walkhoff

- Made 14 days after the Röntgen publication in December 1895 on the initiative of Dr. Walkhoff
- Professor Giesel made these with the help of a small glass photographic plate wrapped in black paper and a sheet of rubber
- Set timer for 25 minutes!



# Early years

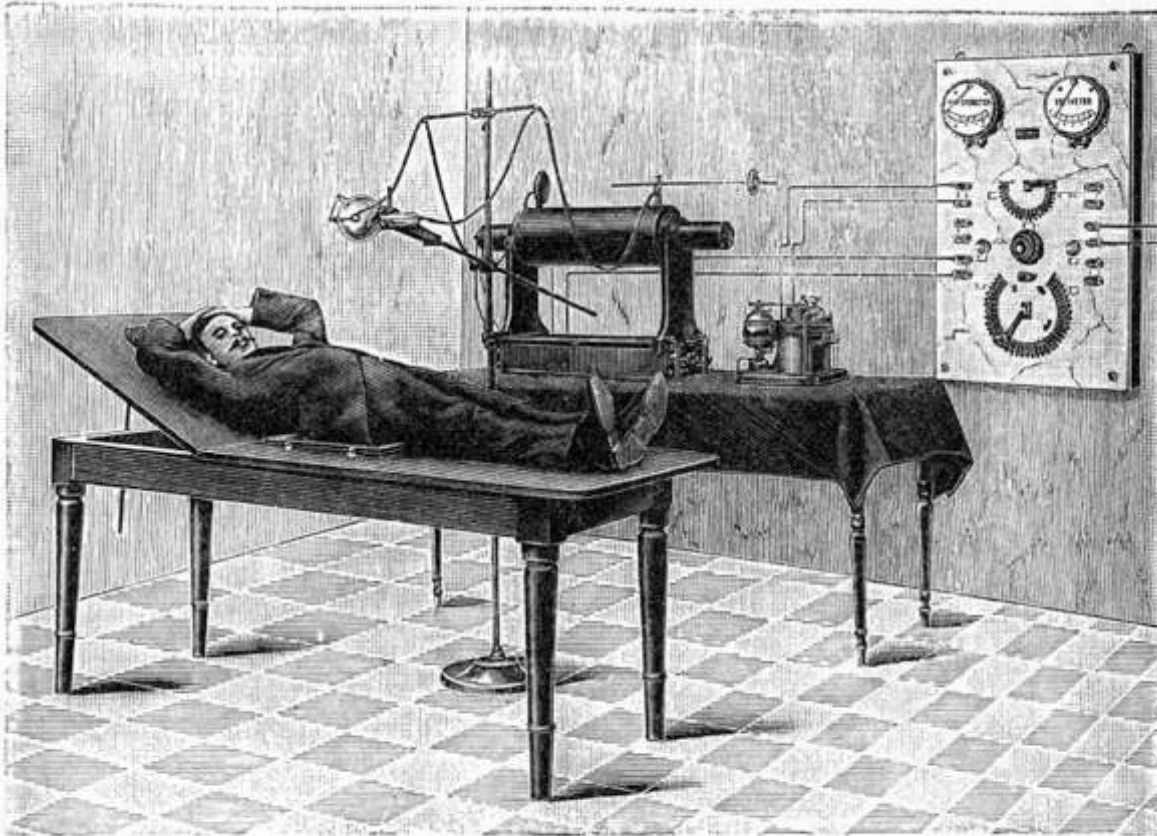

Photographische Aufnahme mit Röntgenstrahlen.

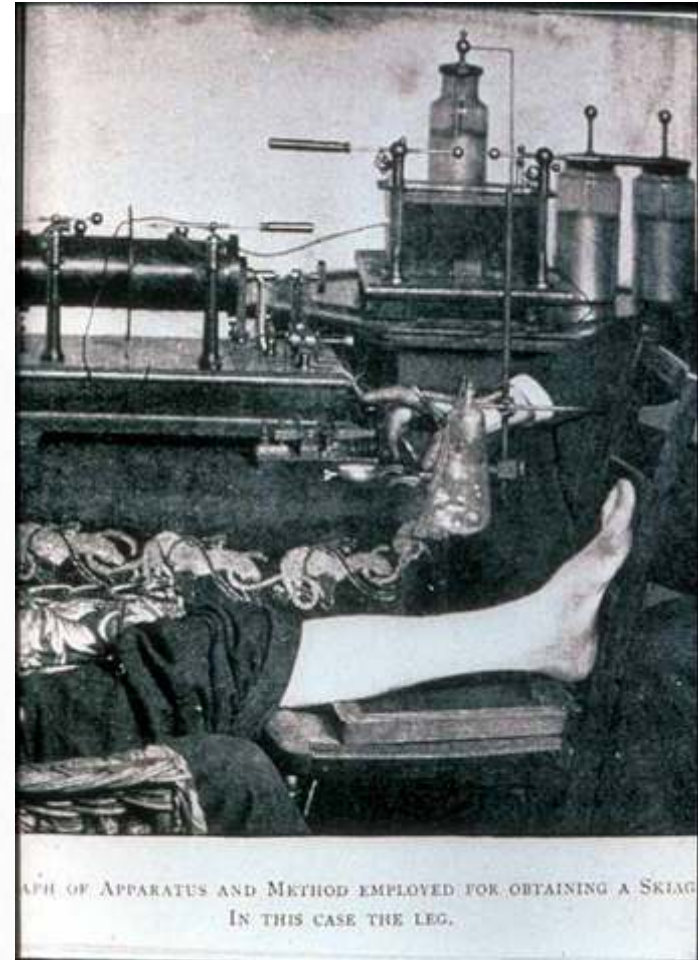

PHOTOGRAPH OF APPARATUS AND METHOD EMPLOYED FOR OBTAINING A SKIAGRAM.  
IN THIS CASE THE LEG.

# Fluoroscopy



# Radiology laboratories



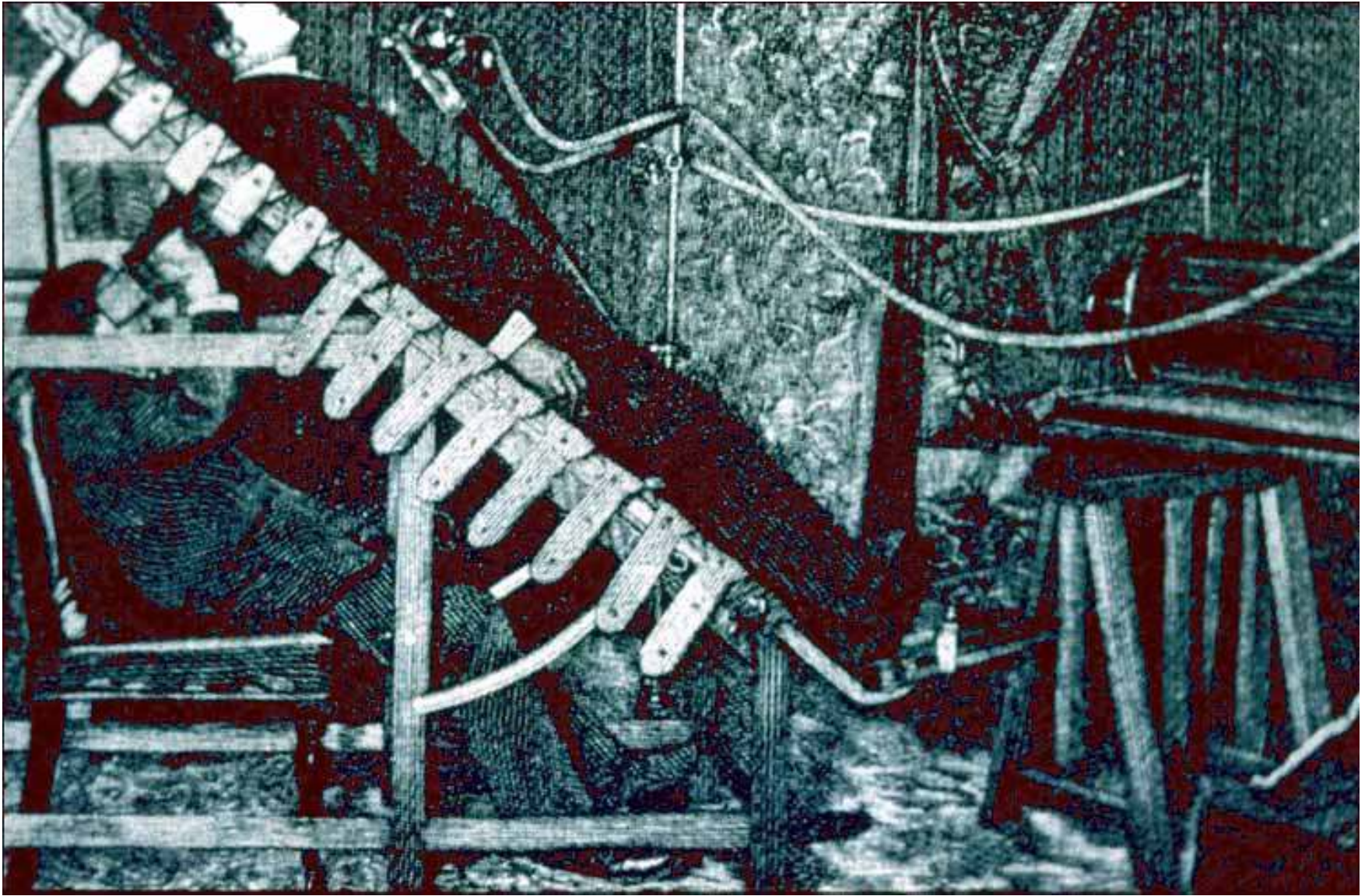

# Early days

The earliest  
manufactured  
dental X-rays  
apparatus

The X-rays tube  
was partially lead-  
shielded for  
protection but  
with exposed  
high-voltage wire  
The output was 10  
mA and 60 kV

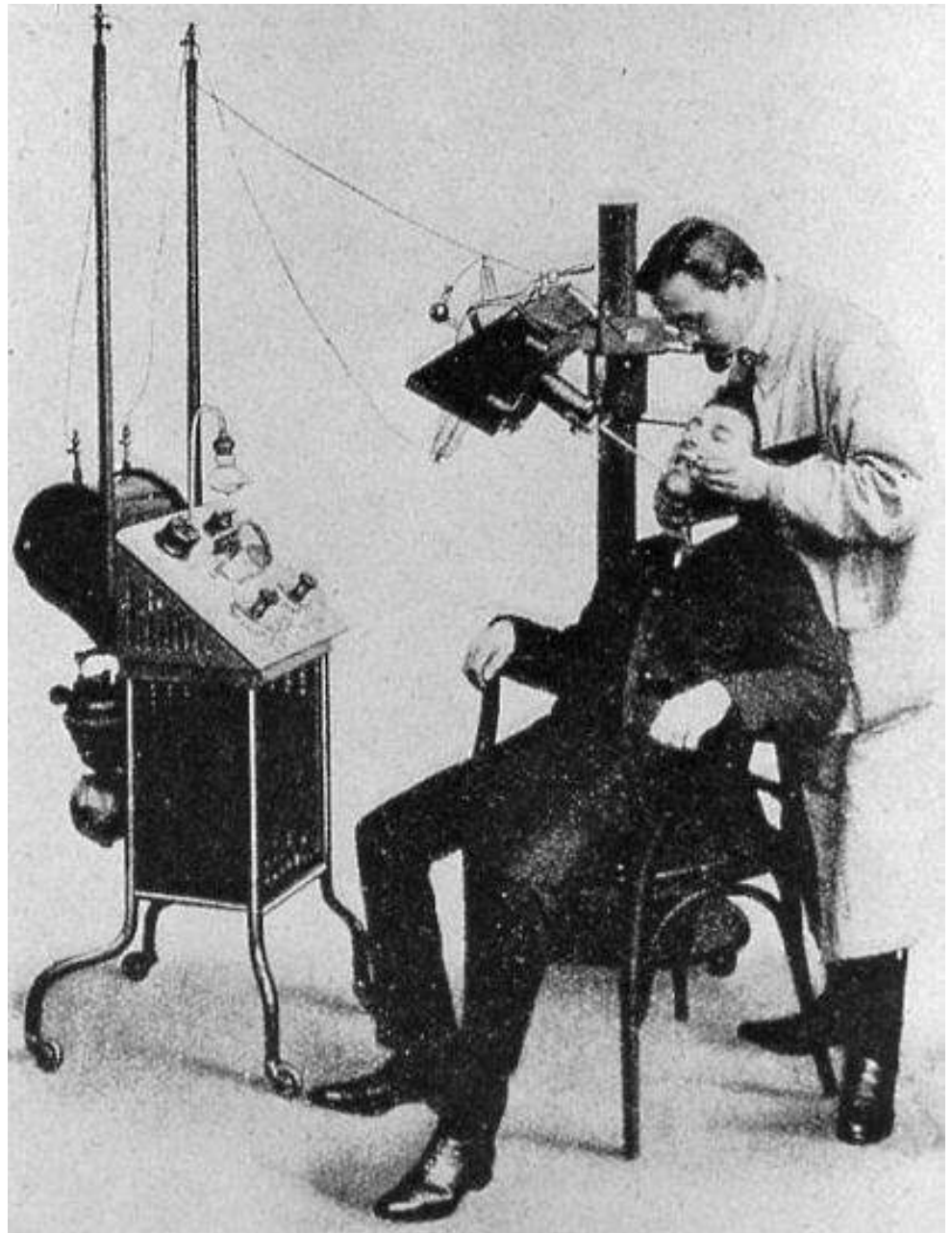

# William H. Rollins

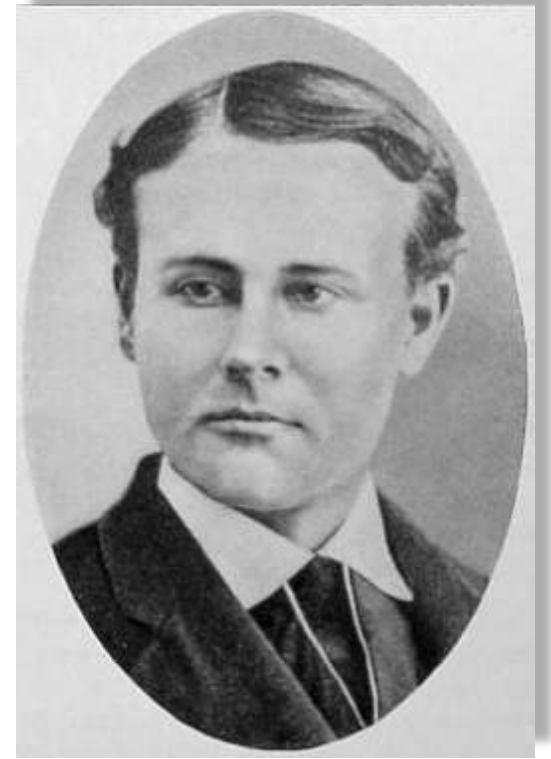

- Earned D.M.D degree from the Harvard dental school in 1875 when he was 21 years old, and the diploma of Doctor in medicine in 1879
- By 1896 practicing dentistry in Boston for 17 years
- With the announcement of Röntgen's discovery begins research on equipment and use of X-rays in Dentistry

# Rollins

In July 1896 he invented an intraoral cassette and intraoral fluoroscope to look at the posterior teeth

Aware of risks to hands at this time - recommends use of a “non-radiable” rubber glove

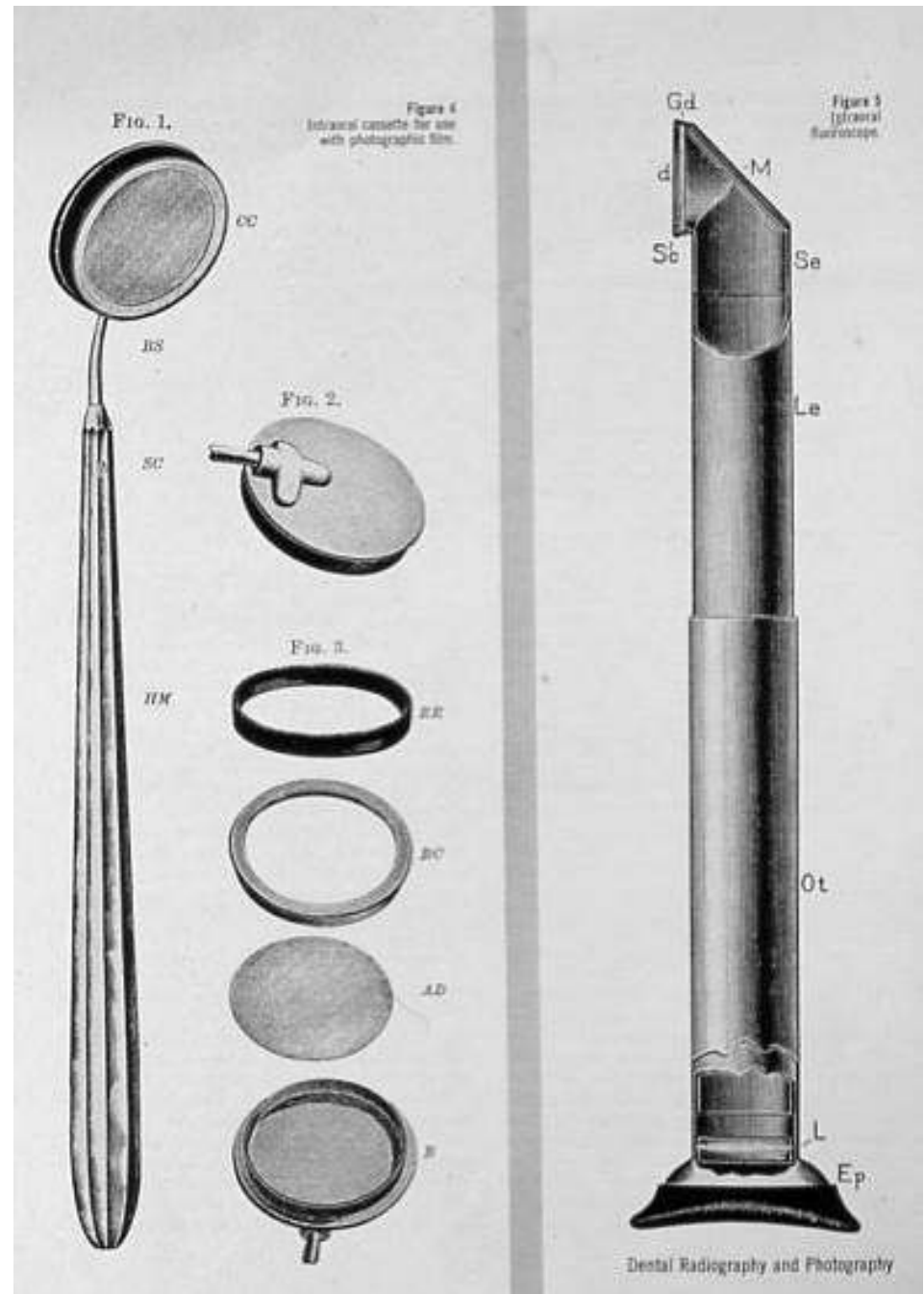

# First Reports of Injury

## **March 1896**

Vanderbilt Professor of Physics John Daniel (1861-1950) persuaded the Dean of the Medical School to sit for an experimental radiograph of the skull. Three weeks later the dean's hair fell out, a result treated with levity by those recording the result

## **August 1896**

“Deleterious Effects of X Rays on the Human Body: Further Evidence that Repeated Exposure to the Rays Produces a Sunburn Effect,” *Electrical Review*

## **Late 1896**

Elihu Thomson - deliberately exposed left index finger for 30 minutes a day for several days and provided accurate observations on the resulting erythema, swelling and pain

## **By end of 1897**

69 cases of skin damage reported



# What caused the burns?

- 1896: Tesla says burns not caused by x-rays but rather by ozone or nitrous acid
- 1898: Burns caused by electricity in absence of X-light
- 1901: Codman EA. **No practical danger from the x-ray.** *Boston Med Surg J* 1901;144:197
- 1901: Rollins W. **X-light can kill animals.** *Boston Med Surg J* 1901;144:173.

# Rollins

Feb. 1901 *X-Light Can Kill Animals*. *Boston Medical and Surgical Journal*

**Methods** Exposed 2 guinea pigs in grounded Faraday chambers for two hours

**Results** They died after 8 and 11 days

## Discussion

- A. “There were many details connected with these experiments which are not given, remembering how many hours of sunlight have been lost through being obliged to read long papers”
- B. Separated the effects of electricity from X-light and “clearly showed what a powerful agent X-light was.”
- C. Need to use this power for new growths in the interior of the body
- D. Recommends three precautions:
  - Those using fluoroscopes should wear glasses of the most non-radiable material that is transparent
  - X-light tube should be in a non-radiable box from which no X-light can escape except the smallest cone of rays which will cover the area to be examined, treated or photographed
  - The patient should be covered with a non-radiable material, exposing only the necessary area

# And again

Jan. 1902: Vacuum Tube Burns. Boston Medical and Surgical Journal

- Repeats previous work but adds two control guinea pigs in same chambers but not exposed to X-light
- Provides a much more complete Methods section
- Exposed animals die, Controls live

# Radiation therapy

April 1902: Some Conclusions from Experiments on Guinea Pigs which are of Importance in the Treatment of Disease by X-Light. BMSJ

- Because of inverse square law source should be distant from patient to avoid over exposure of skin
- Should use low vacuum (low resistance, low kVp) tubes for superficial lesions and high vacuum, high resistance, high kVp tubes) for deep lesions to spare skin
- Argues that experiments should be performed on animals rather than humans! (remember Elihu Thomson)

# Principles of Radiation Protection

Dec. 1903 his list of precautions is extended in [A Grouping of Some of the Axioms Mentioned](#) and include:

- The source should be in a non-radiable tube box allowing for the escape of only the smallest beam usable
- X-light should not strike the observer
- Protect fluorescent screen with leaded glass towards observer
- Use the smallest beam to cover the area of interest
- The patient should be covered with a non-radiable material, exposing only the necessary area
- In using a fluorescent screen, or making photographs, orient central ray of beam normal to plate or film
- The physician should be able to make all adjustments of the X-light without removing his eyes from the image on the fluorescent screen
- When using X-light the apparatus should be sterile
- Use selective filters to remove undesirable radiations

# Prolific author

## NOTES ON X-LIGHT

WILLIAM ROLLINS

NOTES  
ON  
X - LIGHT

BY  
WILLIAM ROLLINS

BOSTON, MASSACHUSETTS  
MCMIV

At least 183 articles from March 1896 - Feb. 1904

- Dental cameras and cryptoscopes
- Technical articles on tube and power supply design and operation
- Nature of cathode rays and X-light
- Radiation protection principles and practical application

Yet his work not widely accepted, until . . . .

# Radiation workers start dying

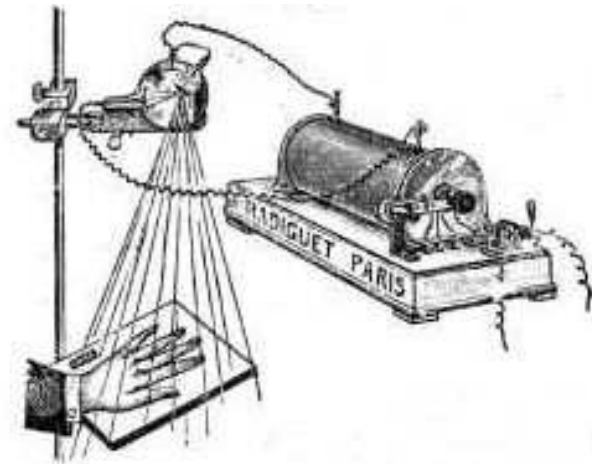

Clarence Madison Dally (b. 1865), a glass blower at Thomas Edison's lab. He suffered severe radiation burns in 1896. Hair fell out & scalp became inflamed & ulcerated. Continued to work with x-rays until his death in 1904 - the first of the radiation workers.

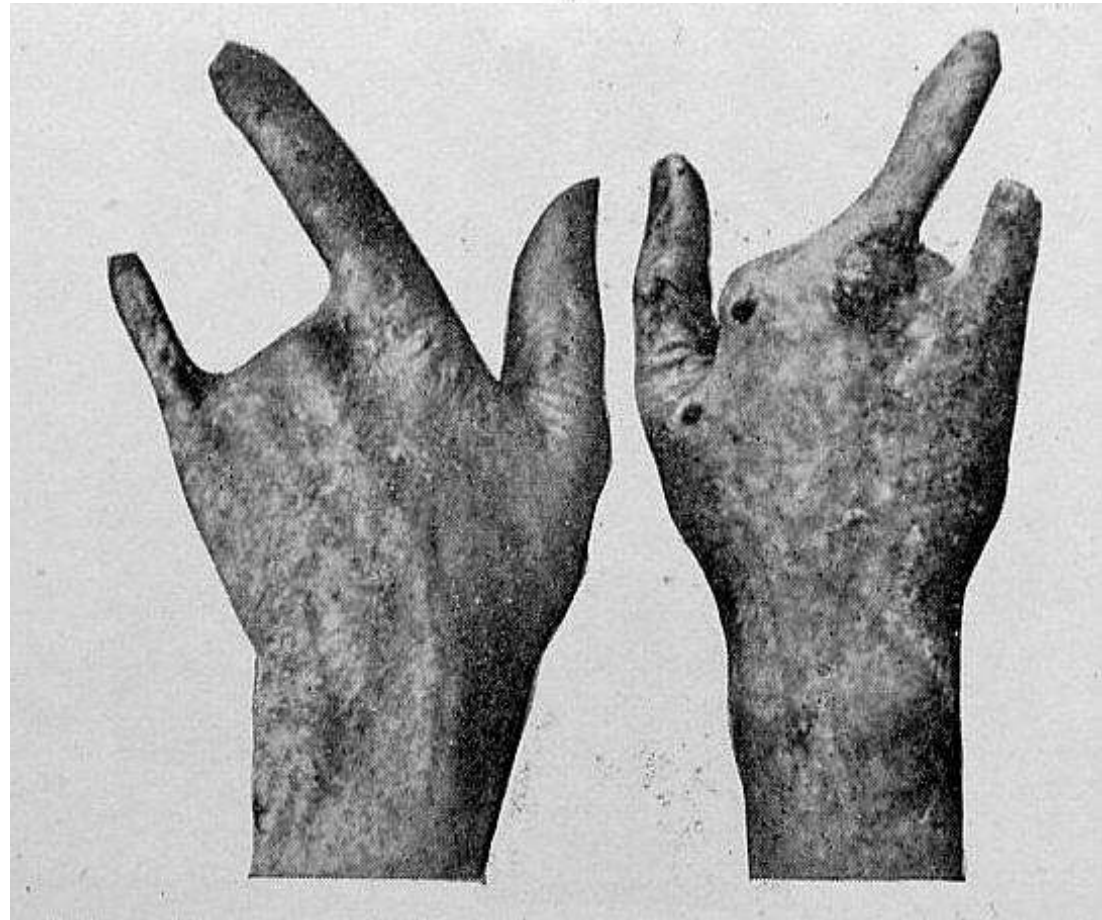

# Mihran Kassabian (1870-1910)

Radiologist and textbook author



# Sister Blandina (1871 - 1916)

1898, started work as radiographer in Cologne

Held nervous patients & children with unprotected hands

Controlled the degree of hardness of the X-ray tube by placing her hand behind of the screen.

After 6 months strong flushing & swellings of hands

Diagnosed with an X-ray cancer, some fingers amputated, then whole hand amputated; whole arm amputated.



# Pioneer deaths

## 1905 Elizabeth Fleischmann-Ascheim

- Known as “the most expert woman radiographer in the world”
- Newspapers published full-page eulogies on “America’s Joan of Arc”

**Louis Andrew Weigel** of Rochester, New York (1854-1906)

**William Carl Egelhoff** of Chicago (1872-1907)

**Wolfram Conrad Fuchs** of Chicago (1865-1908)

**Rome Vernon Wagner** of Chicago (1869-1908)

By 1911 more than fifty cases of x-ray-induced cancer reported.

# C. Edmund Kells

Highly innovative dentist from  
New Orleans

Believed himself to be immune  
to the harmful effects of the  
Röntgen rays

After amputation of three  
fingers followed by his hand  
and then arm, he ended his life  
on May 7, 1928

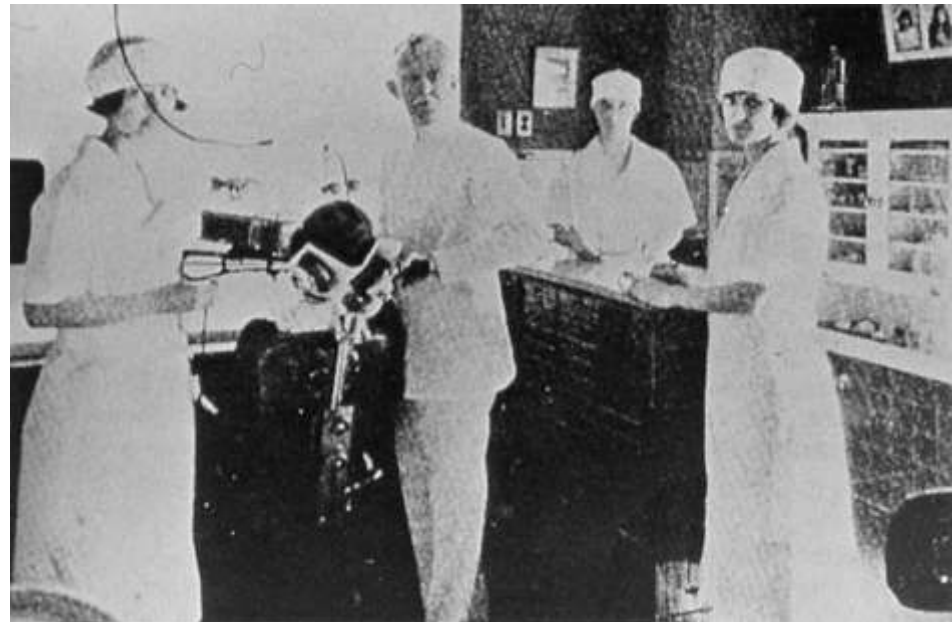

By now people are paying attention

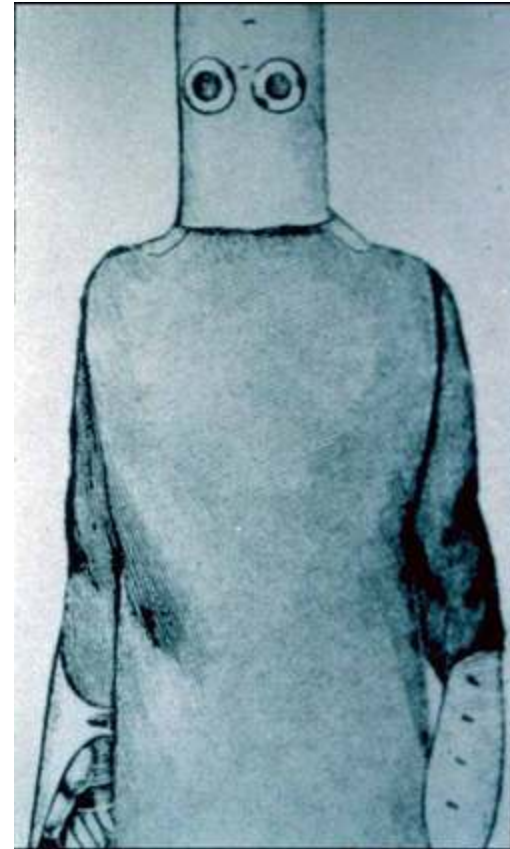
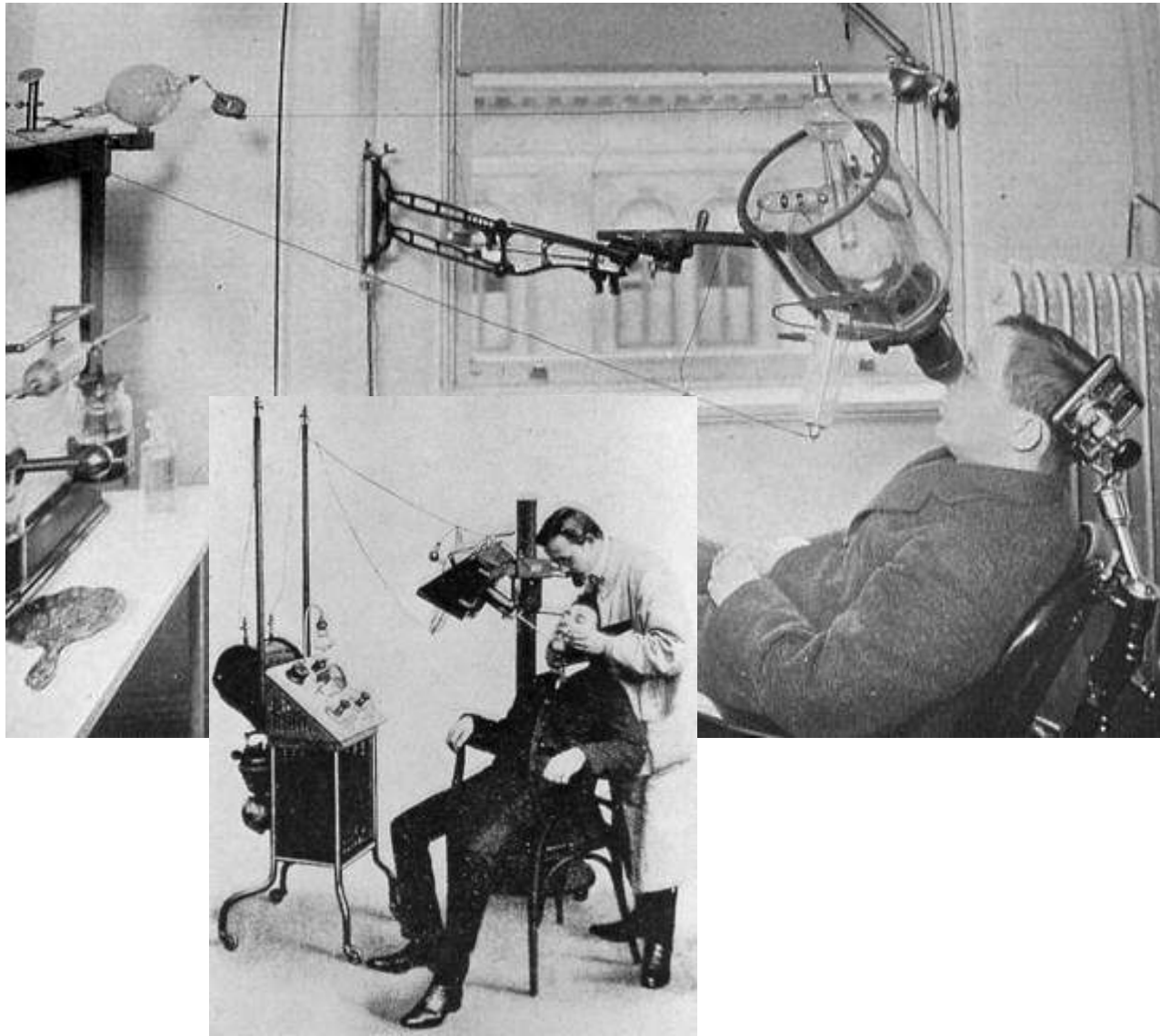

# Collimated beam

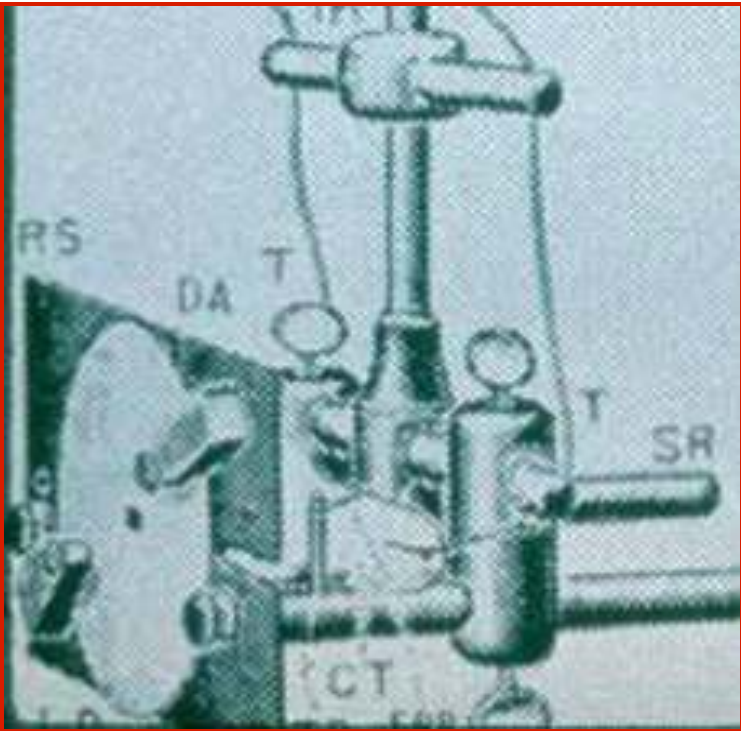
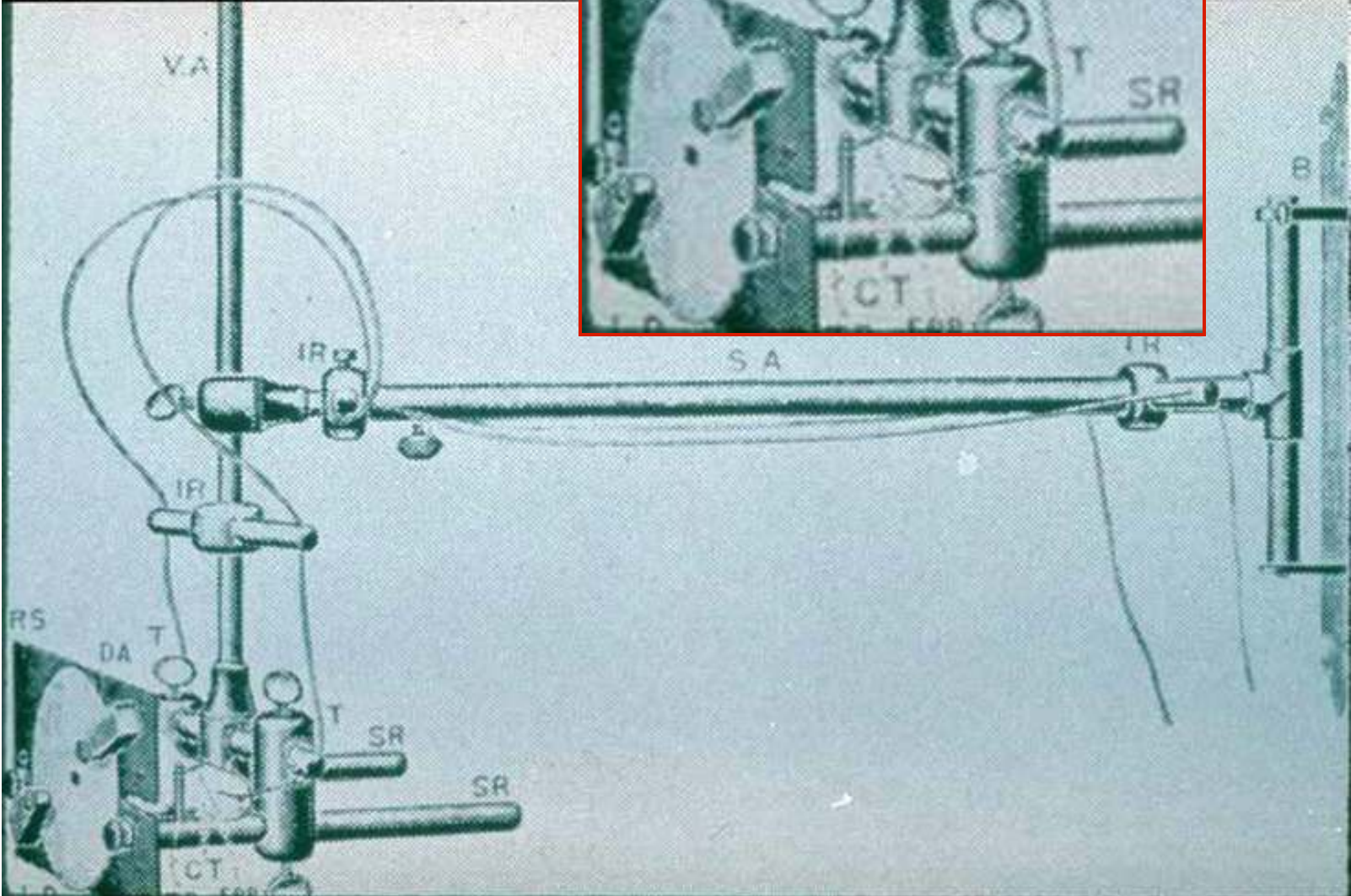

# We remember Rollins as The Father of Radiation Protection

Like Röntgen, he:

- Correctly understood meaning of his early observations
- Reduced observations to practical guidelines
- Worked in clinically relevant areas
- Persevered in his work to improve his observations and educate his colleagues

Retired from dental practice in 1911

1852-1929

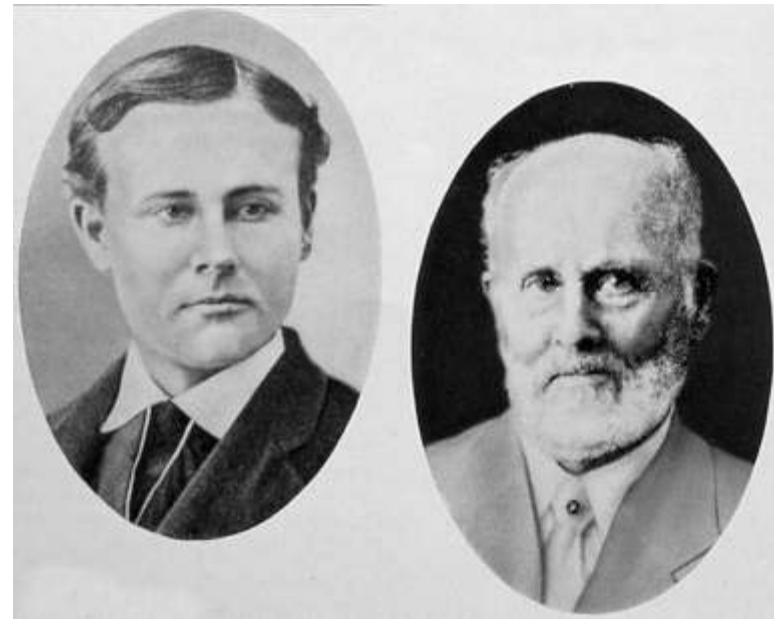

- Credited with opening the Rollins Trail in 1899 from the peak of Mt. Whiteface along the ridge to the original Dicey's Mill Trail on Passaconaway
- Also in 1899, Rollins cleared the McCrillis Trail from Whiteface Intervale to the peak of Mt. Whiteface

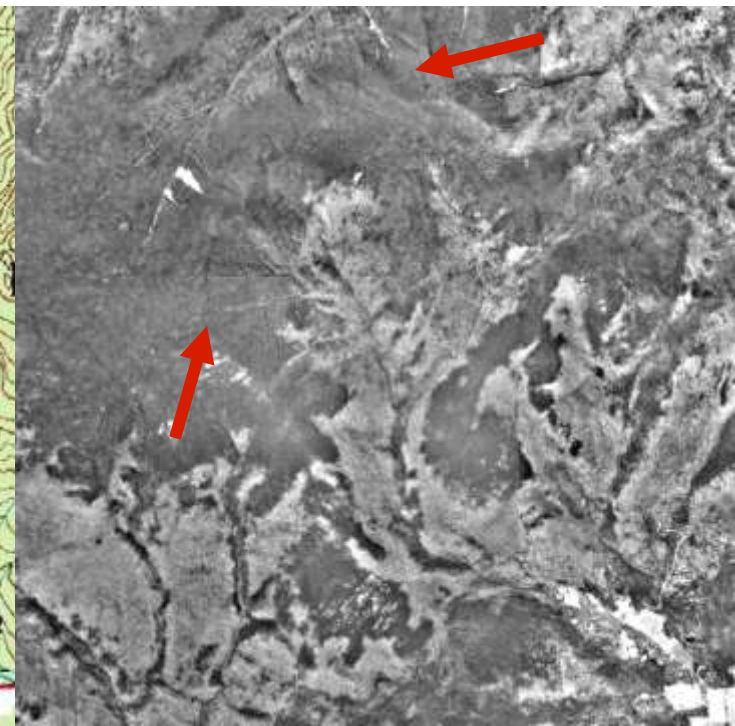
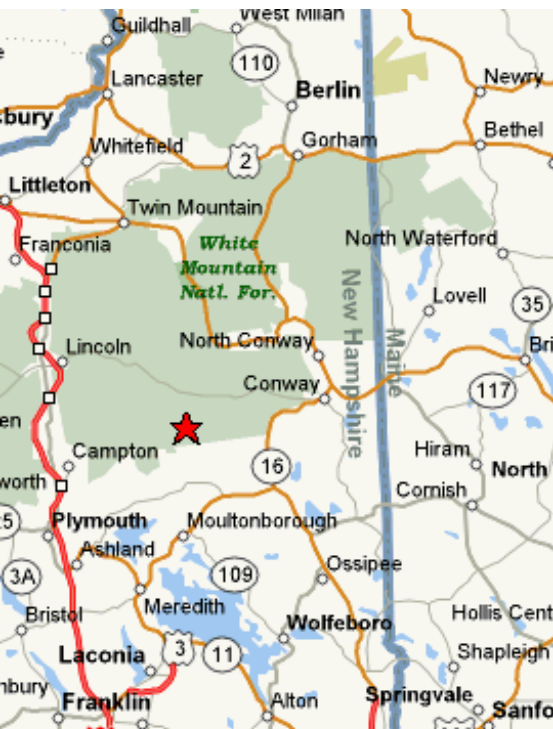

- Carried out studies on hybridization of iris and water lilies, photography, and gardening
- “Canoeists on Great Hill Pond will long remember the gorgeous pink water lilies bred by this unique man”
- A lover of nature, he left lands of shore and forest on Cape Cod as a sanctuary for birds



# The search for overarching principles

Faraday

Geissler

Plucker

Rühmkorff

Hittorf

Crookes

Hertz

Lenard

Röntgen

Rollins

Can we learn lessons that will help predict or enhance likelihood of success?

# The search for overarching principles

History is just one damn fact after another

History is more or less bunk

There is no law of history any more than of a kaleidoscope

But is history so different from other observational sciences:

Astronomy

Geology

Ecology

Paleontology

# The search for overarching principles

Success in understanding principles in such fields comes from observations of natural experiments

- Success of societies on islands with many resources vs. few
- Consequences of collision between galaxies
- Caries rates in  $F1^-$  rich and deprived areas

Success in prediction most likely on broad scales

- Societies with guns will replace stone-age cultures
- But who will win local school board election?

# Traits of successful individuals (partial list)

## **Innate**

- Brains
- Creativity
- Curious
- others

## **Acquired**

- Persistence - a skill that we all have the potential to learn

# Persistence

Hans Bethe 1906-2005

- Discovered carbon-nitrogen cycle and proton-proton reactions that power the stars
- Received Nobel Prize
- He said of this work that he found the answer by “looking through the periodic table step by step. So you see, this was a discovery by persistence, not by brains.”

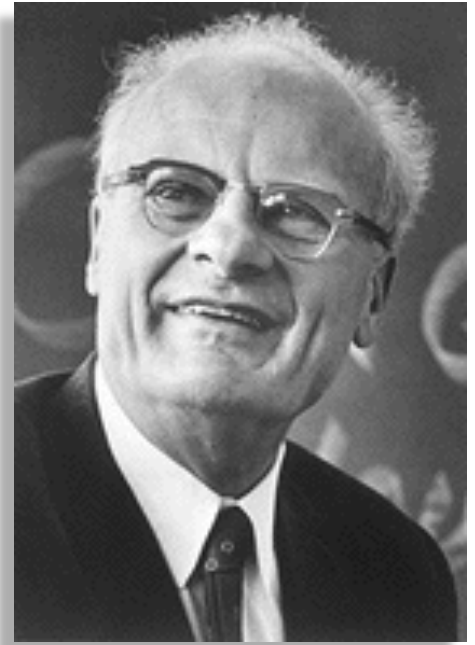

# Persistence



I do know that kind fate allowed me to find a couple of nice ideas after many years of feverish labor.

To Dutch physicist H. A. Lorentz, January 19, 1920

It's not that I'm so smart, it's just that I stay with problems longer.

# Persistence

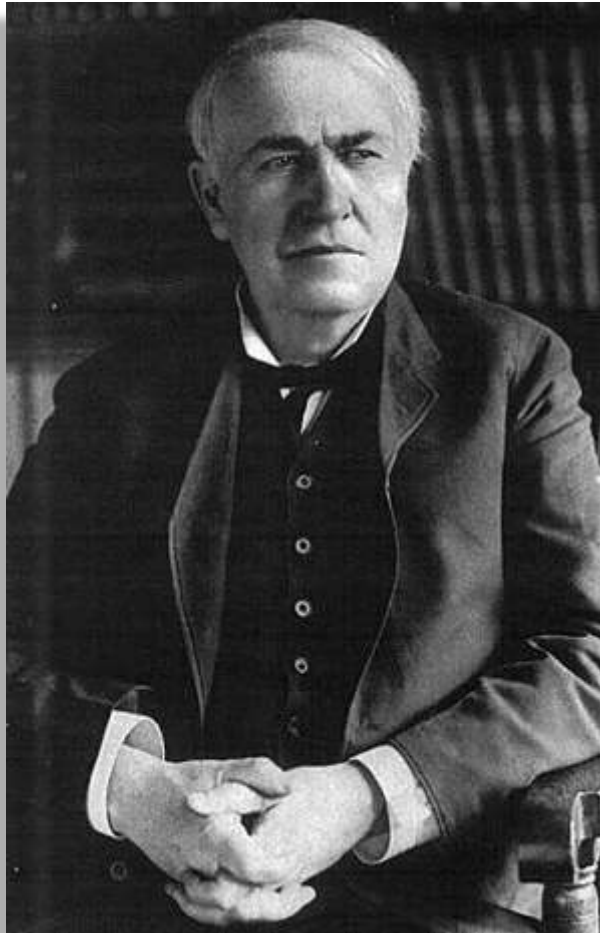

Thomas Edison tested over 3000 filaments before he came up with his version of a practical light bulb



electric light bulb



photograph



kineoscope

“The three things that are most essential to achievement are common sense, hard work and stick-to-it-iveness.....”

# Persistence

- Nothing in the world can take the place of persistence.
- Talent will not; nothing is more common than unsuccessful men with talent.
- Genius will not; unrewarded genius is almost a proverb.
- Education will not; the world is full of educated derelicts.
- Persistence and determination alone are omnipotent.
- The slogan 'press on' has solved, and always will solve, the problems of the human race.



Woodrow Wilson  
Twenty-Eighth President  
1913-1921



Persistence

And you all have persisted here long enough

**Thank You**

# Acknowledgements

## Images

- Radiology Centennial, Inc.
- A CENTURY OF RADIOLOGY: Dept. Radiology, Penn State University
- Health Physics Historical Instrument Collection
- The Cathode Ray Tube site
- Sparkmuseum
- The X-rays : their first applications in dentistry by Claude ROUSSEAU ancien Président de la SFHAD Ex-conservateur du Musée Pierre Fauchard
- The University of Michigan Health Physics Web Site
- Idaho State University: The First Fifty Years of Radiation Protection
- First FRCR Examination in Clinical Radiology Radiation Hazards and Dosimetry by John Saunderson; Radiation Protection Adviser

## Texts and Articles

- In the Name of Science: Suffering, Sacrifice, and the Formation of American Roentgenology by Rebecca Herzig
- Diamond, J. Guns, germs, and Steel Norton, 1999
- Glasser, O. Dr. W. C. Rontgen, Charles C Thomas, 1958
- Rhodes, R. The making of the Atomic Bomb, Simon & Schuster, 1986
- Rollins, W. Notes on X-Light, 1903
- Rollins, William Herbert: Journal of Last Years, 1918-1929